

# 2010 Rating Application - Bay Area Multihull Association

The Rating Committee has no responsibility for the seaworthiness or safety of yachts rated & cites US SAILING Fundamental Rule 4, "It shall be the sole responsibility of each yacht to decide whether or not to start or to continue to race".

Boat Name	_____	Name	_____
Sail Number	_____	Street	_____
Boat Model	<u>Sprint 750</u>	City, State, Zip	_____
Manufacturer	<u>Corsair Marine</u>	Email Address:	_____
Year Built	_____	Day Phone:	_____
Marina	_____	Evening Phone:	_____
Slip Number	_____	Emergency #:	_____

## Do you want an ODR (One Design Rating)?

Yes <input type="checkbox"/>	No <input type="checkbox"/>	N / A <input type="checkbox"/>
This is a:	<b>Source of the information Provided</b> (Circle/check all that apply)	
Unmodified Class Boat <input type="checkbox"/>	Class Rules <input type="checkbox"/>	Sailmaker <input type="checkbox"/>
Modified Class Boat <input type="checkbox"/>	Designer <input type="checkbox"/>	Owner Measurement <input type="checkbox"/>
Non-Class (Custom) <input type="checkbox"/>	Sales Brochure <input type="checkbox"/>	Measurement Cert. <input type="checkbox"/>
Cut/paste <input checked="" type="checkbox"/>		

Descriptions of terms used for sails, hull measurement & sailing weight are on following pages. Sail Areas, Luff Lengths, Foot & LP generally come from the sailmaker. Where possible, please give measurements in metric or feet & decimals. Please provide drawings or pictures showing side & end views of your boat from deck to bottom & attach to the application if a modified or custom boat.

**Mainsail** 20XX sailmaker

**Area:**  
P (luff)  
E (foot)  
MGH  
MGT  
MGU  
MGM  
MastCirc  
Full Batten or Soft

**Jib / Genoa** (largest) 20XX sailmaker

**Area:**  
Luff Length  
LPG  
Leach  
Foot  
LuffL.roach + or -  
Le.roach + or -  
Ft.roach + or -  
Mid-Girth

**Screacher** 20XX sailmaker

yes/no  
**Area:**  
Scr.Luff1  
LPG  
Scr.Luff2 (leach)  
Scr.MG  
Scr.Foot  
  
Sc.SMG as % Sc.SF 0%

**Asymmetric Spin** (largest) 20XX sailmaker

yes/no  
**Area:**  
SLU (luff perimeter)  
SLU (leech perimeter)  
SMG  
SF (foot.perimeter)  
  
SMG as % SF 0%

**Symmetric Spin** (largest)

yes/no  
**Area:**  
SL  
SSMG  
SSF (foot.perimeter)  
  
SMG as % SF 0%

**Displacement** (Load.cell metric or Mfg Displ)

Wt Boat sails, motor  
CG Safety, dry(gas,h2o)  
WE  
Weight Sailing  
WCD Weight Crew  
Declared  
  
Rated Weight 0

US Sailing and/or ISAF ERS methods of sail measurement may apply above, not class rules. Longest Luff Lengths from Class Rules & Maximum Sail Areas and will be assumed if not provided. Weight Sailing will be lightest boat in Class unless weighed w/inspection.

**Hull**

Length Overall:  
Waterline length  
Maximum Beam  
Maximum Draft  
FOC Fwd Overhang  
AOC Aft Overhang

**Hull - Foils**

Daggerboard (y/n)  
Centerboard (y/n)  
Ctbd Fairing (y/n)  
Keel(s) (y/n)  
  
Lifting Foils (y/n)

**Other**

Masthead Spin(yes/no)  
Masthead Scr.(yes/no)  
Sprit Length  
Rigging (SS, synthetic)  
  
Holding Tank(s)

**Engine(s)**

Inboard (hp x type)  
Outboard (hp x type)

**Propeller (s)**

1 x feather/fold	2 x feather/fold
1 x fixed (blades)	2 x fixed (blades)

**Modifications** Describe modifications / comments/ trapeze(#) or hiking straps below

I certify that my vessel conforms to the configuration indicated above and understand that a BAMA ratings certificate will be issued based on this information, valid only for the indicated configuration.

Electronically  
Signature of Owner \_\_\_\_\_ Date \_\_\_\_\_

<b>Office Use Only</b>	<b>PHRF</b>	<b>Amount Paid</b>
<b>TCF</b>		

## Sample - Metric

## Basic Sail Area Measurements

Corsair Sprint 750 sail # Generic  
Corsair Sprint 750 Class Std.Sail Areas

It is preferred that a sail loft actually measure the sails & provide Areas w/mid-girths & metrics, or fill out this sheet. An alternative: a competitor may measure the sails. Please use feet and tenths of feet, or metric for measurement.

Mast Circumference		0.481		Class Rules Sail Areas			
Measured Sails				Imp.	Metric	Imp sq.ft	Metric sq.m
<b>Mainsail</b>	23.696	SA= (Foot*2+MGM*3+1.5*MGU+MGT+.5*HW)*Luff/8		Imp.	Metric	255	23.69
Luff / P	9.840			32.29	9.843		
Foot / E	3.270			10.75	3.277		
HW / MGH	0.760	Head mainsail shall extend @ right angles not more than		2.50	0.762		
MGT	1.260	Maximum MGT (max 7/8 point girth) =		4.13	1.257		
MGU	1.950	Maximum MGU (max 3/4 point girth)=		6.40	1.949		
MGM	2.720	Maximum MGM (max 1/2 point girth)=		8.92	2.718		
MGL	0.000	Maximum MGL (max 1/4 point girth) =		0.00	0.000		
<b>Jib - Large</b>				Imp.	Metric	Imp sq.ft	Metric sq.m
Jib	11.648	SA= Luff * LP * .5		29.50	8.992	125.00	11.61
Luff	8.992	Maximum Luff =		8.50	2.591	CTOA	
LP	2.591	Maximum Overlap =		0.00	0.000	ISAF±Roach	12.58
Leech						(max/min)-1	8%
Mid-girth		Maximum Mid-Girth = Del Par 5.9.2c, add 4" roach.ft		5.25	1.60		<a href="#">pic.Link</a>
Height (=vlg)	8.452	Jib Height = 0.94 * Luff.Length					
<b>Screacher</b>				Imp.	Metric	Imp sq.ft	Metric sq.m
Luff	24.343	SA= Luff * LP * .5		32.25	9.830	262.00	24.34
LP	9.830			16.25	4.953		
smg screecher	4.953	Estimate (scaled from pencil.paper, no penalty config.)		0.00	7.075		
sf screecher	7.075	Estimate (scaled from pencil.paper)		0.00	14.350		
<b>Asym.Spin.Large</b>				Imp.	Metric	Imp sq.ft	Metric sq.m
SLU / Luff	56.742	SA = (Luff+Leech)*(Foot + 4*Mid Girth) / 12		38.25	11.659	626.00	58.16
SLE / Leech	11.659	Head to tack (luff) maximum length =		31.17	9.500		
ASF / Foot	9.500	Clew to head (leech) maximum length =		21.58	6.579		
ASMG / mid-girth	6.579	Tack to clew (foot) maximum length =		21.00	6.401		
ISAF ERS	6.401	SMG =					
	56.742	SA= (SLU+SLE) x .25 x ASF + (ASMG-.5ASF) x (SLU+SLE)/3					
<b>One Design Rules:</b>				Imp	Metric		
5.9.1 Mainsail							
5.9.1b P=				32.29	9.84		
5.9.1c E=				10.75	3.28		
5.9.1a Head (MGH)				2.50	0.76		
5.9.1d Maximum MGT (max 7/8 point girth)=				4.13	1.26		
Maximum MGU (max 3/4 point girth)=				6.40	1.95		
Maximum MGM (max 1/2 point girth)=				8.92	2.72		
Maximum MGL (max 1/4 point girth)=					0.00		
Leech, Plan A sail plan - exceed					0.00		
5.9.2 Jib							
5.9.2a Luff - head to tack maximum length=				29.50	8.99		
5.9.2b LPG=				8.50	2.59		
Leech -clew to head maximum length=					0.00		
Foot - tack to clew maximum length=					0.00		
5.9.2c Mid-Girth (deleted par.)				5.25	1.60		
5.9.4 Spinnaker dimensions: Luff, Leech, Foot and mid-girth combined not to exceed 1344 inches [3414 cm]							
sailplan Luff - Head to tack maximum length=				38.25	11.66		
Leech - clew - head maximum length=				31.17	9.50		
Foot - Tack to clew maximum length=				21.58	6.58		
Spin Mid-Girth(SMG)= Adjusted -8" from sailplan to be Class Legal				21.00	6.40		
				1344.00	34.14		
5.9.3 Screacher							
5.9.3b Luff - head to tack maximum=				32.25	9.83		
5.9.3c LP=				16.25	4.95		
Foot - tack to clew maximum=					0.00		
Leech - leech maximum length=					0.00		

**Mainsail**

- a) The HEAD shall be defined as the point of intersection of the line of the Luff, including the boltrope, and the highest point of the sail perpendicular to the Luff. The Head Width shall be measured from the HEAD.
- b) Luff is measured as the distance between two points along a line parallel to the sail Luff from which lines drawn at 90 degrees intersect the highest point on the HEAD or the lowest point on the Foot, respectively.
- c) The Foot is measured as the two farthest points along the Foot.
- d) The cross width measurements shall be taken from the seven-eighths, three-quarter, and one-half points on the Leech, located when the HEAD is folded to the Clew for the half height point, and when the HEAD is folded to the half height point to determine the three-quarter point. The seven-eighths point is located by folding the Head to the three-quarter point. Girth is measured as the shortest distance from Leech points to Luff, including the boltrope.

**Spinnaker**

- e) For purposes of spinnaker measurement, the mid-girth shall be measured from the one-half point on the Luff to the one-half point on the Leech. These one-half points shall be found by folding the Head to the Tack for the one-half point on the Luff, and folding the Head to the Clew for the one-half point on the Leech.

**Jib**

- f) For purposes of headsail measurement, the Tack is defined as the point where the Luff and Foot, if extended, would intersect each other. The Head is defined as the point of intersection of the line of the Luff, including the boltrope, and the highest point of the sail perpendicular to the Luff. The Clew is the point where the Leech and Foot, if extended, would intersect each other.
- g) The diagonal (LP) is defined as the shortest distance from the Luff to the Clew.
- h) The mid-girth is measured by folding the Head to the Clew to find the mid-leech. The distance from the mid-leech to the closest point on the Luff is the mid-girth

**Screacher**

- i) For purposes of Screacher measurement, the Tack is defined as the point where the Luff and Foot, if extended, would intersect each other. The Head is defined as the point of intersection of the line of the Luff, including the boltrope, and the highest point of the sail perpendicular to the Luff. The Clew is the point where the Leech and Foot, if extended, would intersect each other.
- j) The diagonal (LP) is defined as the shortest distance from the Luff to the Clew

# Mainsail Measurement - Sample

Corsair Sprint 750 - US Sailing Girth Points

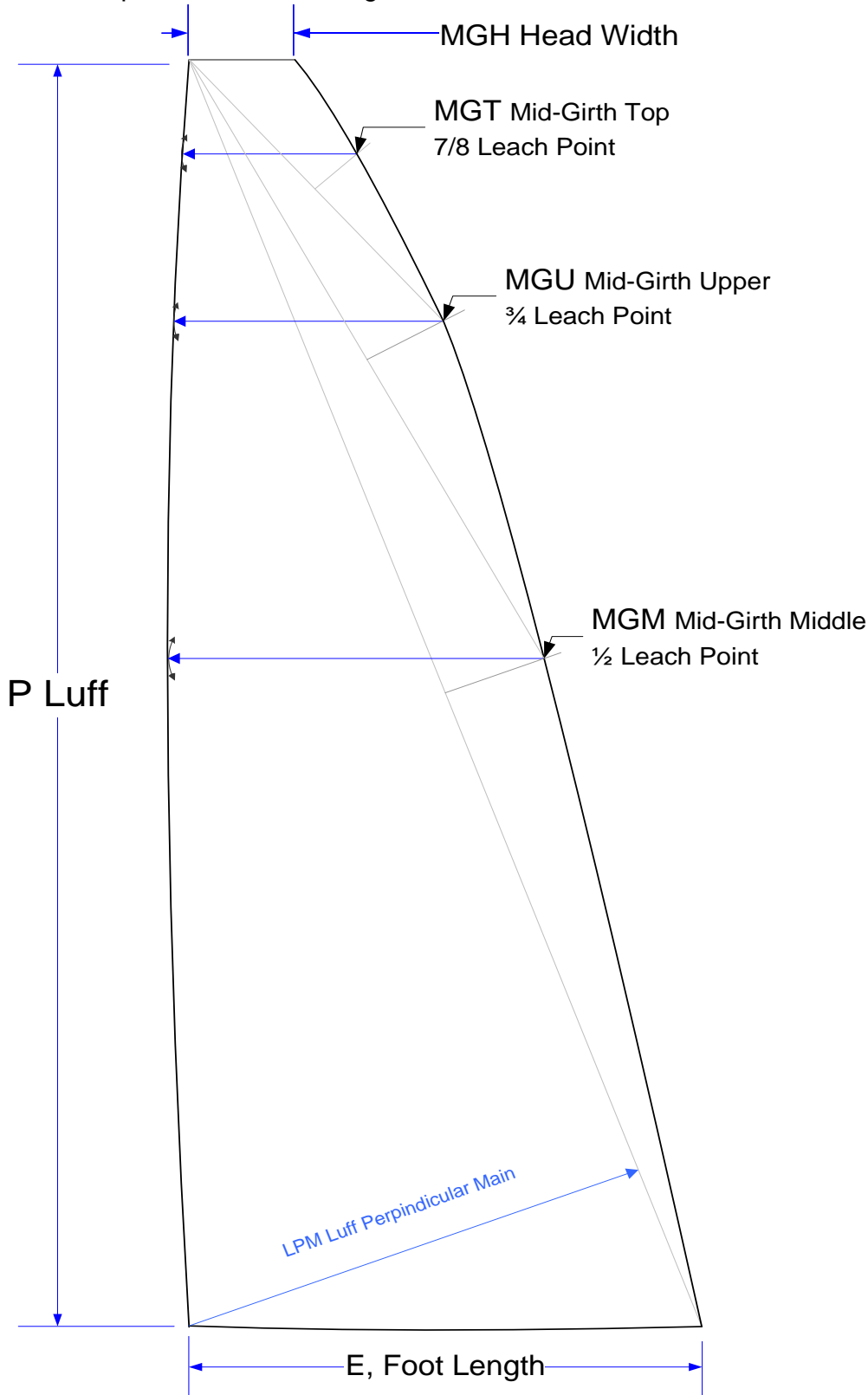

Mainsail	Metric m <sup>2</sup>	Imperial ft <sup>2</sup>
<b>Area</b>	<b>23.70</b>	<b>255.18</b>
Luff / P	9.840	32.29
Foot / E	3.270	10.75
HW / MGH	0.760	2.50
MGT	1.260	4.13
MGU	1.950	6.40
MGM	2.720	8.92
MGL	0.000	0.00

LPM auto-calculated for most boats; sets sail efficiency

**ISAF Equipment Rules of Sailing (ERS)  
Corsair Sprint Class Rules**

**CM - Area of Mainsail** (template equation, sample data)

77.370	$S1 = ((h + h1)(a - a1) + (a1 \times h))/2$
2.565	$S2 = c \times h2/2$
0.002	$S3 = 2/3 \ c3 \times h3$
0.007	$S4 = c4 \times h4/2$
0.001	$S5 = 2/3 \ c5 \times h5$
0.002	$S6 = 2/3 \ c6 \times h6$
1.257	$S7 = 2/3 \ a \times h7$
0.001	$S8 = 2/3 \ b \times h8$
<b>81.204</b>	$CM^* = (S1+S2+S3+S4+S5+S6+S7+S8) \ m^2$
	$CM = (CM^* + \text{Area of Mast} + \text{Area of Boom}) \ m^2$
	Non-Rotating Masts add no Sail Area
	Area of Mast = (Total Length x Perimeter / 2) m <sup>2</sup>
	Area of Boom = (Total Length x Height) m <sup>2</sup>
	Larger Multihulls Mast Area = (MC/2 * a); a = P.luff or VLM

h	7.25
h1	0.14
a	20.96
a1	0.13
c	20.52
h2	0.25
c3	0.10
h3	0.03
c4	0.11
h4	0.12
c5	0.06
h5	0.02
c6	0.06
h6	0.04
b	0.07
h7	0.09
h8	0.03

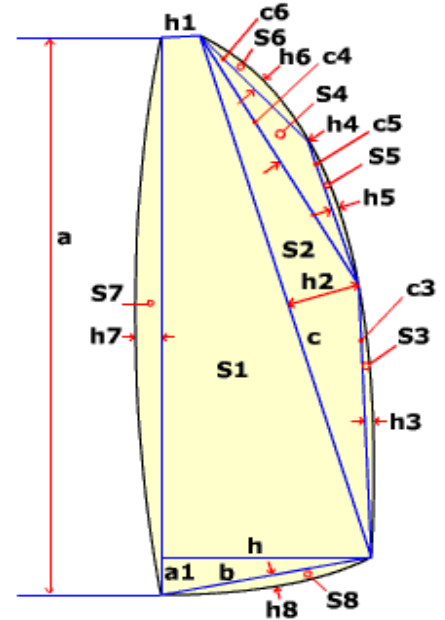

**CJ - Area of Jib** Sprint750 Jib: max luff, lp, mid-girth = 63" 2006 Class Rules

11.65	$S9 = a \times h / 2$
0.20	$S10 = 2/3 \ b \times h10$
1.83	$S11 = 2/3 \ c \times h11$
-0.27	$S12 = 2/3 \ a \times h12$
<b>13.40</b>	$CJ = ( S9 +or- S10 +or- S11 +or- S12 ) \ m^2$
	<a href="#">link</a>
15%	(CJ/S9)-1
	Mid-Girth 63" 1.6m
144.27	Sq.Ft

a	8.99
h	2.59
b	2.97
h10	0.10
c	8.04
h11	0.34
h12	-0.05
	1.60

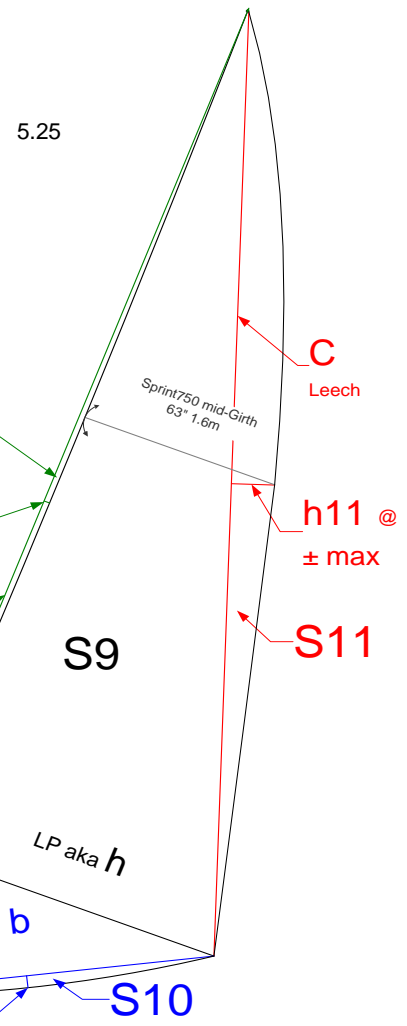

**CSPI - Area of Spinnaker** (Sample Sprint 750)

<b>56.745</b>	$CSPI = SF \times (SL1+SL2)/4 + (SMG^* - SF/2) \times 2/3 \ (SL1+SL2)/2 \ m^2$
---------------	--

SL1	11.66
SL2	9.50
SF	6.58
SMG	6.40

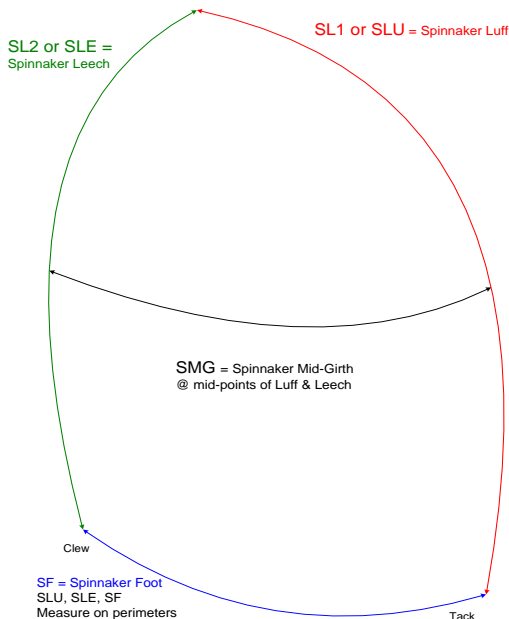

.where  $SMG \geq 75\%$  of SF  
SMG % SF

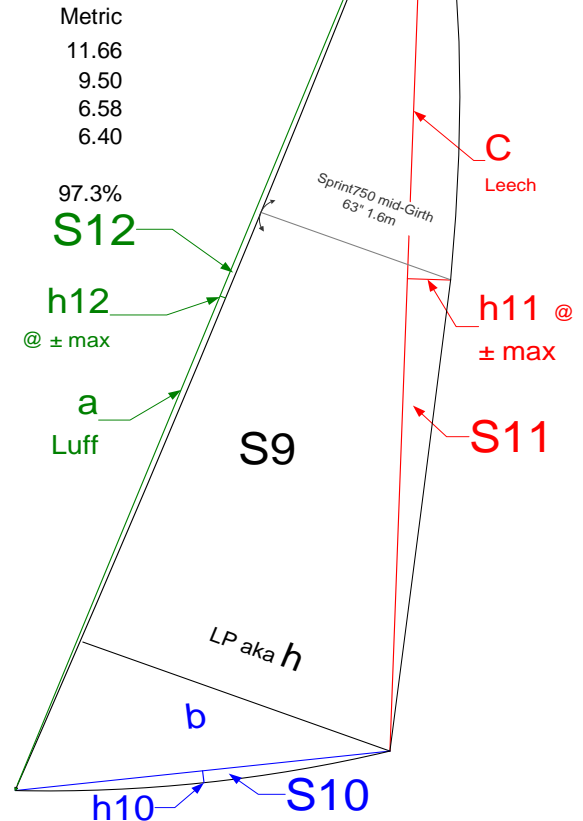

# Texel AUS/NDL MEASUREMENT FORM

Weight Sailing lb 2061.0 **Texel AUS/NDL Inventory Form**  
 Weight Sailing kg 934.9 **Equipment Declaration Form**

Date: September 1, 2010

This is to **state** that the yacht **Corsair Sprint 750 AUS 77, Zorro2** weighs the above w/the following in a dry condition (no:water, gas). All equipment "Declared" is part of the "Inventory" that must remain on the boat for racing including a set of racing sails & **U.S. Coast Guard required equipment** applicable to the boat size. Texel Weight Equipment (WE) of individual items is waived based on inclusion of same in Sailing Weight.

Equipment	Description	Equipment	Description	WE items (list)	Kg
Engine/s	Outboard	Mainsails	One (1) on boom		
Generator	No	Mizzens			
Anchor 1	Yes, [Fortress] [3kg]lb/kg	Headsails	One (1) Jib, furling		
Anchor 2		Headsails	One (1) Screacher		
Chain (size/m)	Yes[6mm]link.dia. [3]m	Spinnaker #1	One (1) Spinnaker		
Rode (dia/m)	Yes [8mm] dia. [25]m	Spinnaker #2			
Moorings	dock lines	Screacher	One (1) w/furling gear		
Fenders	Yes (2)	Other sails			
Drogues	No	Spare sheets	Minimal		
Tools(kgs)	Yes	Mattresses No.	None		
Spares(kgs)	Minimal	Seat cushions	No		
Dinghy	No	Bunk cushions	No		
Liferaft	No	Stove type	Yes		
Outboard(hp)	Yes [Nissan], [5] hp min.	Refrig	No		
Battery #1 Amp/Hrs	30 amp hour	Awning	No		
Battery #2 Amp/Hrs	TBD (no)	T.V.	No		
VHF Radio	handheld	Video	No		
Solar panels	No	Radar	No		
Gas bottles (kgs)	No	Wine Rack	No		
Safety Category (Offshore)	Inshore - Coast Guard Req.	Other (list)			
Other (list)					

Where it is simpler to weigh items such as tools and spares, use kgs, where it is simpler to count items, use numbers etc. For example [Tools - 10kg], [Mattresses - 4], [Chain 8mm - 50 metres]. Otherwise describe, [Engine - 9.8 hp Yamaha outboard 27hp Yanmar Diesel] or mark to show it is carried [Video - X]. WE may be used for Offshore Races requiring Category X equip.

WM 934.9 Offshore WE 0  
 WM 934.9 Inshore Wt.Sailing = (Wt.Measured + Wt.Equipment)

**SIGNED:**  
**MEASURER**

**OWNER** A.Brand

2082 Gross: Zorro2, dry, all sails  
 0 Lifting Bridle, tared  
 -1 NIST test deviation @ 2,000 lbs  
 -20 Subtract: inspection found x Liters gas in tank, minimal food, no (water-beer)  
 2061 Net: Zorro2 dry, all sails

## Mast Circumference

Boat	MC		Date	Comments
Native, Newick Tri	0.908	w	08/20/09	Blue Tape, taper above spin.halyard (img_0060...)
Humdinger, Acapella Tri	0.800	w	03/20/10	Owner TB.Verified
Formula 40 Tuki	0.760	c	07/28/09	Blue Tape
Antrim 30	0.750	t	04/05/10	TB.verified, Erin #28910
Formula 40 Shadow	0.719	a	04/04/09	Dirty blue tape, 1st pass, taper above hounds
D-Class Cat Adrenaline Marstrom	0.700	c	05/30/09	Assumption, not measured pre-Delta.Ditch @RichmondYC
Viva 27 Cat Sass	0.600	a	05/30/09	Measure pre-Delta.Ditch @RichmondYC
Contour 34SC	0.585	a	01/08/10	Blue.Tape, measured by owner
Corsair 31RS Leneman	0.554	a	05/30/09	Blue Tape, C-31RS #28543 Prime Directive
D-Class Cat Rocket88	0.495	a	07/15/10	Dirty, 1st pass
D-Class Cat Beowulf V Marstrom	0.483	c	06/01/10	Correction, Corsair 28R Section
Corsair 28R Marstrom	0.483	c	03/31/10	Blue Tape C-28R, Alameda Marina
Corsair 31R Marstrom	0.483	c	04/22/09	Blue Tape C-31R #135 Roshambo, Alameda Marina
Corsair Sprint 750	0.481	a	05/02/09	Blue Tape Sprint 750 #70 Afterburner, Alameda Marina
Corsair 24 Mk II	0.397	a	08/01/09	Blue tape C-24MkII #006 Emma Jean, Alameda Marina
Multi23	0.356	c	04/07/09	M. Leneman, US Tri.Nationals, Standard Section

Mast Circumference: wrap paper or tape around mast above boom

Mast Area added to mainsail area IFF mast rotates

Mast Area =  $1/2 * \text{Mast Circumference} * P$  ( mainsail luff, Vertical Luff Mainsail )

No Correction Factor (CF) on airfoil shape

CF - Carbon Mast may be added later (ref: Multi2000 CF.carbon-mast)

a: aluminum

w: wood composite

t: tuttle carbon honeycomb composite

# Rated Length Examples

**Corsair Sprint 750:** Sample Forward Overhang Component (FOC) Australia (10 boats)

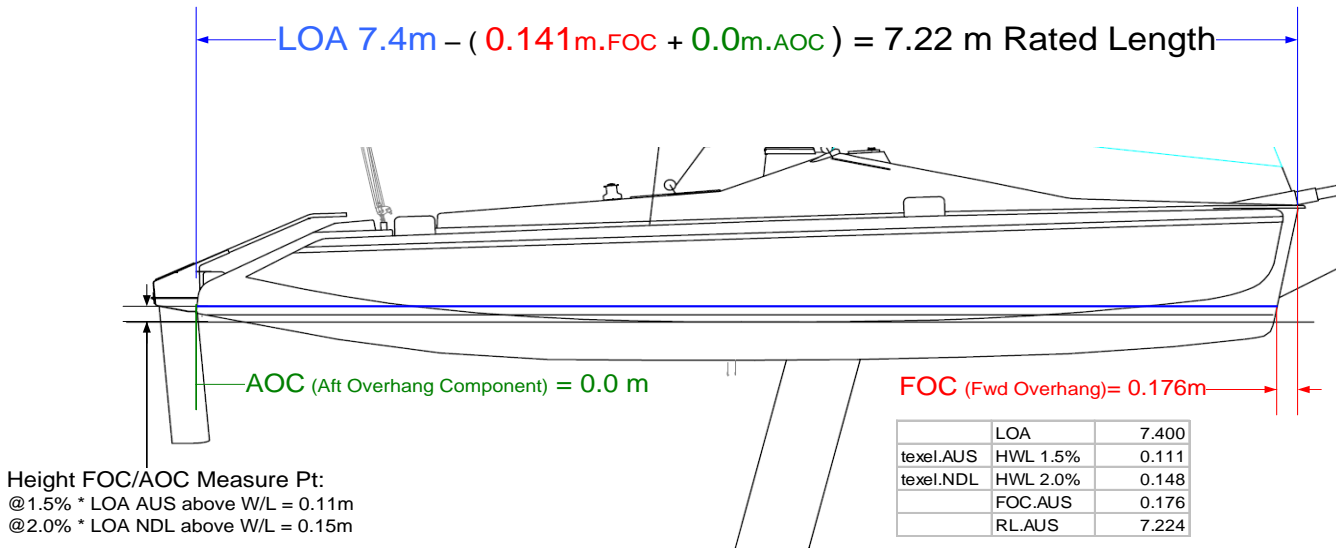

**Corsair 28-R:** Sample Forward Overhang Component (FOC) Australia & Thailand (10 boats)

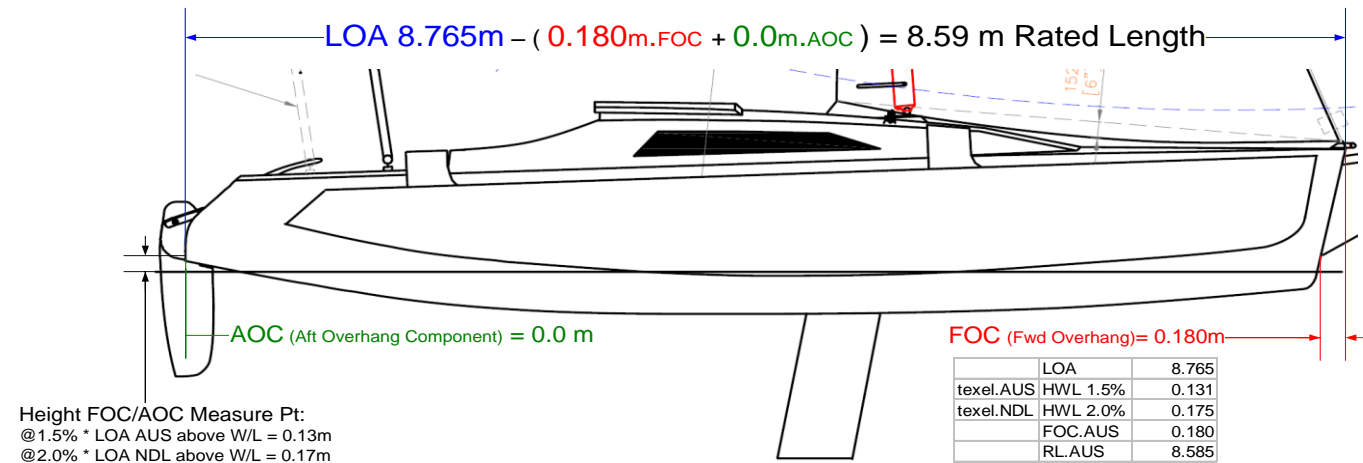

**Gemini105MC Mood Indigo:** Preliminary Forward Overhang Component (FOC)

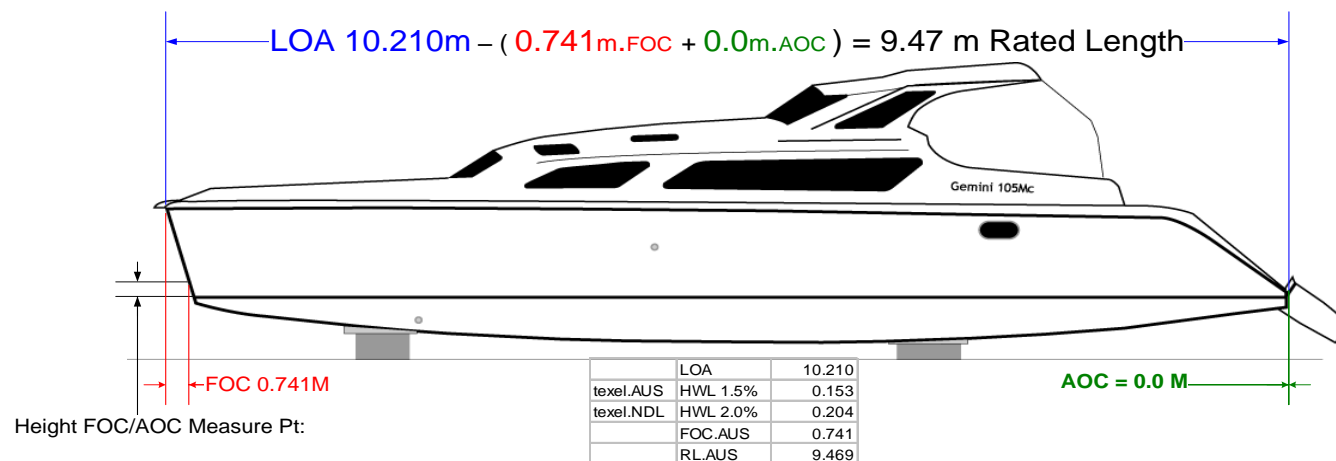



**NOTE: The values on this worksheet are not used for Texel ratings, but for storage of measurements of extra sails for future possible changes.**

Genoa #  
 LLg  
 LPG  
 FG  
 frg + or -  
 LG  
 lrg + or -  
 llrg + or -

<b>0</b>

Area Genoa 2 **0.00**

Genoa #  
 LLg  
 LPG  
 FG  
 frg + or -  
 LG  
 lrg + or -  
 llrg + or -

<b>0</b>

Area Genoa 3 **0.00**

Genoa #  
 LLg  
 LPG  
 FG  
 frg + or -  
 LG  
 lrg + or -  
 llrg + or -

<b>0</b>

Area Genoa 4 **0.00**

Spinnaker #  
 SF  
 SL1  
 SL2  
 SMG  
 Area of Spinnaker  
 SMG as % SF

<b>0</b>
<b>0.00</b>
Must be >75%

Spinnaker #  
 SF  
 SL1  
 SL2  
 SMG  
 Area of Spinnaker  
 SMG as % SF

<b>0</b>
<b>0.00</b>
Must be >75%

Spinnaker #  
 SF  
 SL1  
 SL2  
 SMG  
 Area of Spinnaker  
 SMG as % SF

<b>0</b>
<b>0.00</b>
Must be >75%

Screecher #  
 ScrF  
 ScrL1  
 ScrL2  
 ScrMG  
 Area of Screecher  
 SMG as % SF

<b>0</b>
<b>0.00</b>
Must be >50%

Screecher #  
 ScrF  
 ScrL1  
 ScrL2  
 ScrMG  
 Area of Screecher  
 SMG as % SF

<b>0</b>
<b>0.00</b>
Must be >50%

Screecher #  
 ScrF  
 ScrL1  
 ScrL2  
 ScrMG  
 Area of Screecher  
 SMG as % SF

<b>0</b>
<b>0.00</b>
Must be >50%